

U-Band Overwrappers

- Transit / Secondary Packaging Solution
- Sustainable Material Options
- Reduced Material Quantities
- Recyclable Materials
- Formulated Low Tack Peelable Hot Melt Glue
- High Line Speed integration

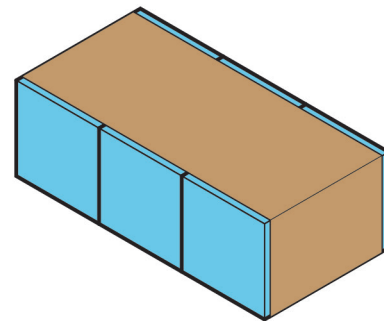

Model	TM Series
Speed	60 bundles per minute
Band Width	80-400mm



Standard fitments include:

- Beckhoff / Siemens / Allen Bradley PLC & HMI
- Simple operation and maintenance
- Large pack size capability
- External side-loading film reel
- Quick-release size changeover

Production integration options:

- Single pack delivery - Automatic Multi-pack Bundling
- Multi-pack delivery - Hand Loading

Optional fitments include:

- Heat-sealable paper
- Plain Kraft paper with hot melt
- Print registration facility
- Automatic product collator
- Inline front-feed or side-feed conveyor layout
- Existing Machinery Conversion (TM/TMX Series)
- Online printing / coding
- Product Serialisation

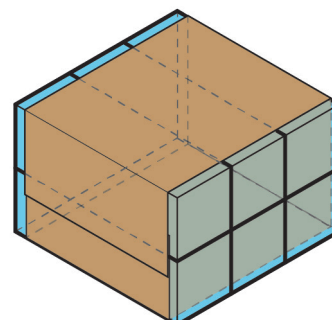
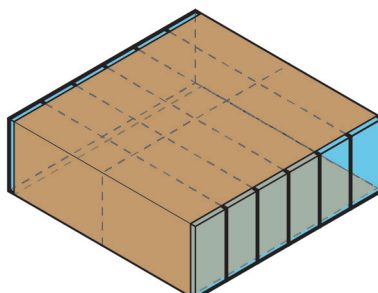
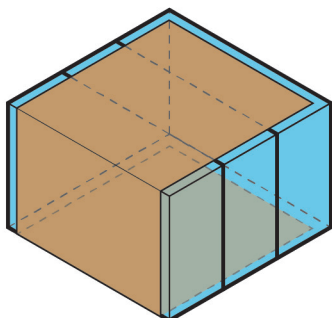



reduce



protect



secure

Marden Edwards, founded more than 65 years ago, is the world leader in the development, design, manufacture and supply of overwrapping and packaging machinery. Over 11,000 overwrapping systems have been manufactured in our UK factories and supplied into more than 150 countries worldwide.

A complete range of tuck and fold overwrapping machines cover a wide range of applications for a variety of products, formats, and performance. We have a comprehensive worldwide network of trade partners to ensure the permanent availability of expertise and service local to you.



OVERWRAPPING TECHNOLOGY

2 Nimrod Way, East Dorset Trade Park,
Wimborne, Dorset, BH21 7SH, UK

Tel: +44 (0) 1202 861200
info@mardenedwards.com
www.mardenedwards.com

Connect with us

